

Grounding

All electrical systems must be grounded in accordance with local and national standards. Grounding provides protection from electrical shock, voltage surges and static charge build up.

The figures in **Appendix A** provide information for grounding the tower and Skystream at the service panel by means of the ground lead coming from the yaw terminals of the turbine.

Appendix B provides information for grounding the tower according to the National Electric Code (USA) and IEC 60364-5-54. Information about grounding electrodes, grounding conductors, and connections is provided.

The turbine must be grounded to the tower as depicted below.

Note: The AC output neutral is NOT bonded to ground within Skystream. The AC neutral is bonded to ground at the AC service panel.

The instructions in this section and Appendix A are provided as reference, local electrical codes and standards have precedence over these instructions.

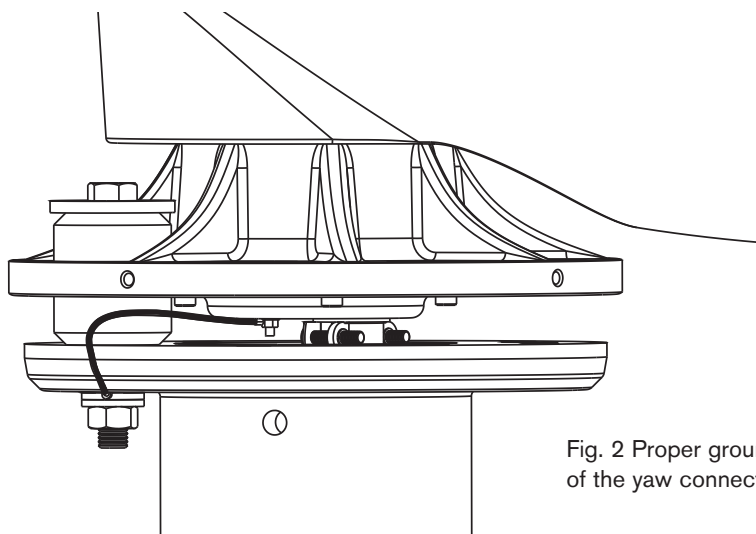

Fig. 2 Proper grounding of the yaw connection

Utility Panel Connections

Skystream connects directly into your electrical panel. Wiring will vary with local zoning authority and utility. Refer to Appendix A for drawings for each voltage, frequency and phase configuration. Some installations will require a visible lockable disconnect switch located next to the electrical metre and/or at the base of the tower. The disconnect switch is utilized by your local utility in the event of a power outage to ensure no voltage is placed on the utility line during repair. Again, it is extremely important to install in accordance with local and national zoning regulations.

Note: Only 20 Amp circuit breakers may be used to connect Skystream to AC service panel. Refer to wiring diagrams in **Appendix A**.

Electrical Connections To Skystream

CAUTION – Be sure power is turned off when making electrical connections.

The following section provides directions for completing the main power connections to the Skystream yaw assembly. The connections are most easily accomplished with Skystream on the ground as would be the case when utilizing a tilt up tower.

If the installation does not incorporate a tilt up tower, the connections may still be made on the ground by utilizing a sufficient length of cable to connect Skystream to the nearest junction point. If, for example, an electrical disconnect box will be installed at the base of the tower, connect enough cable to Skystream to make the connections at the disconnect box – leave some extra cable for connections. The wire connections can then be made on the ground, Skystream hoisted to the top of the tower and the cable “lowered” down the tower and Skystream bolted to the tower.

- Position Skystream on its side to access the wire terminals.
- Remove approximately 5 cm of protective sheathing from cable and strip approximately 1 cm of insulation off wire leads.
- Note the maximum wire size that can be connected directly to Skystream is #6 Metric Wire Size or #8 AWG. Refer to Wire Sizing Section of this manual for instructions on selecting correct size wire.
- Pass cable through strain relief cover so approximately 2.5 cm of cable sheath protrudes through the cover.
- **230 V, 50 Hz, 1 Phase systems:** Connect the brown, blue and green/yellow wires to the matching corresponding color coded terminals on Skystream yaw. There is no wire connection to bare yaw terminal as shown in **Fig 3**. Tighten wire terminal screws to 2.3-2.5 N-m.

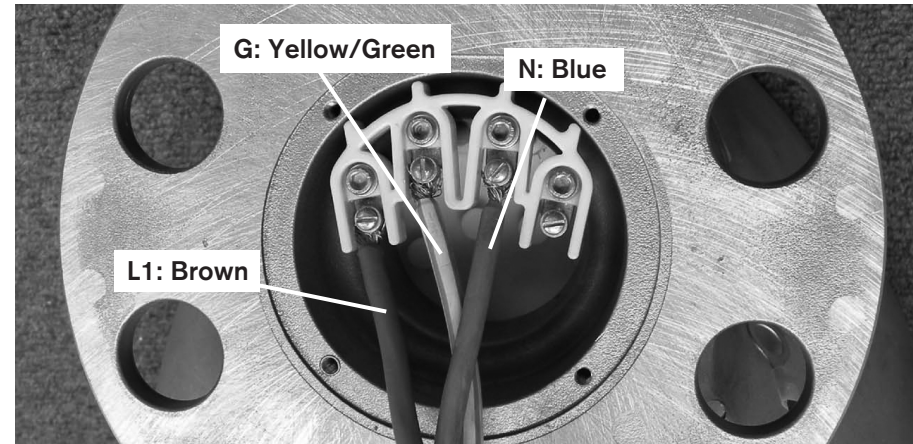



Fig. 3 Wire run to the yaw connection (230V, 50Hz, single phase).

Wiring Symbol Definitions - 230 V, 50 Hz, Single Phase Systems

L1 = Line 1, AC Line Voltage, Brown Wire (230V, 50 Hz, systems)

N = AC Neutral, Blue Wire, (230V, 50 Hz, systems)

G = Gnd. = AC Ground, Green/Yellow Wire

 Indicates AC Ground



Caution: Make sure AC power is switched “OFF” before proceeding with installation.

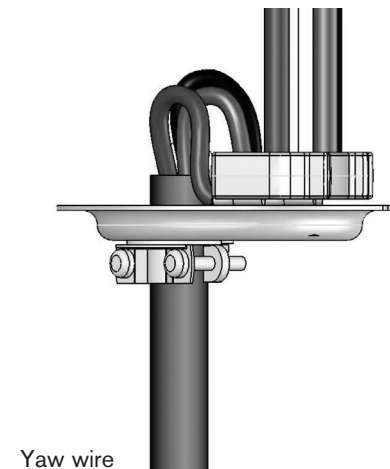



Caution: Electrical Shock Hazard - use extreme care when making electrical measurements on live electrical systems.

After making connections, turn on power and measure voltages at terminals. See table below:

	L1 - N	L1 -L2
120 / 240 VAC, 60 Hz, Split Phase	120 VAC	240 VAC
120 / 208 VAC, 60 Hz, 3 Phase	120 VAC	208 VAC
230 VAC, 50 Hz, 1 Phase	230 VAC	-----
120 VAC, 60 Hz, 1 Phase	120 VAC	-----
127/220 VAC, 60 Hz, 3 Phase	127 VAC	220 VAC

- With power still on, wait approximately 5 minutes and attempt to rotate main blade shaft; blade should be noticeably easier to turn than with power off.
- Turn off power and verify that Skystream has returned to its “braked” mode. If Skystream fails this test check connections and repeat test – test **MUST** be passed before proceeding.
- With power turned off position the wires as depicted in accompanying figure and secure strain relief cover using four M5-0.8 x 12 socket head screws. Tighten strain relief clamp to secure cable.

Lightning Protection

The Skystream 3.7 turbine is designed to withstand over voltages and surge currents (6kV, 3kA, 8/20 μ s) caused by **INDIRECT** lightning strikes or switching operations according to the Standard for Interconnecting Distributed Resources with Electric Power Systems (IEEE 1547) . For this protection to be effective, it is necessary to ensure that over voltages at the Skystream connection terminals will not be higher than the above values of the surge test.

To provide this over voltage protection against **DIRECT** lightning strikes; a **Type 1 lightning current arrester**, that reduces over voltages to a level below 6 kV but is capable of discharging very high currents, much larger than those handled by surge protective devices present inside Skystream is required.

Note: Refer to Appendix C for specific instructions on the selection of a Lightning Protection System.