

Proprietary rights are included in the information disclosed herein. This information is submitted in confidence and neither the document nor the information disclosed herein shall be reproduced or transferred to other documents for manufacturing or for any other purpose except as specifically authorized in writing by Southwest Windpower.

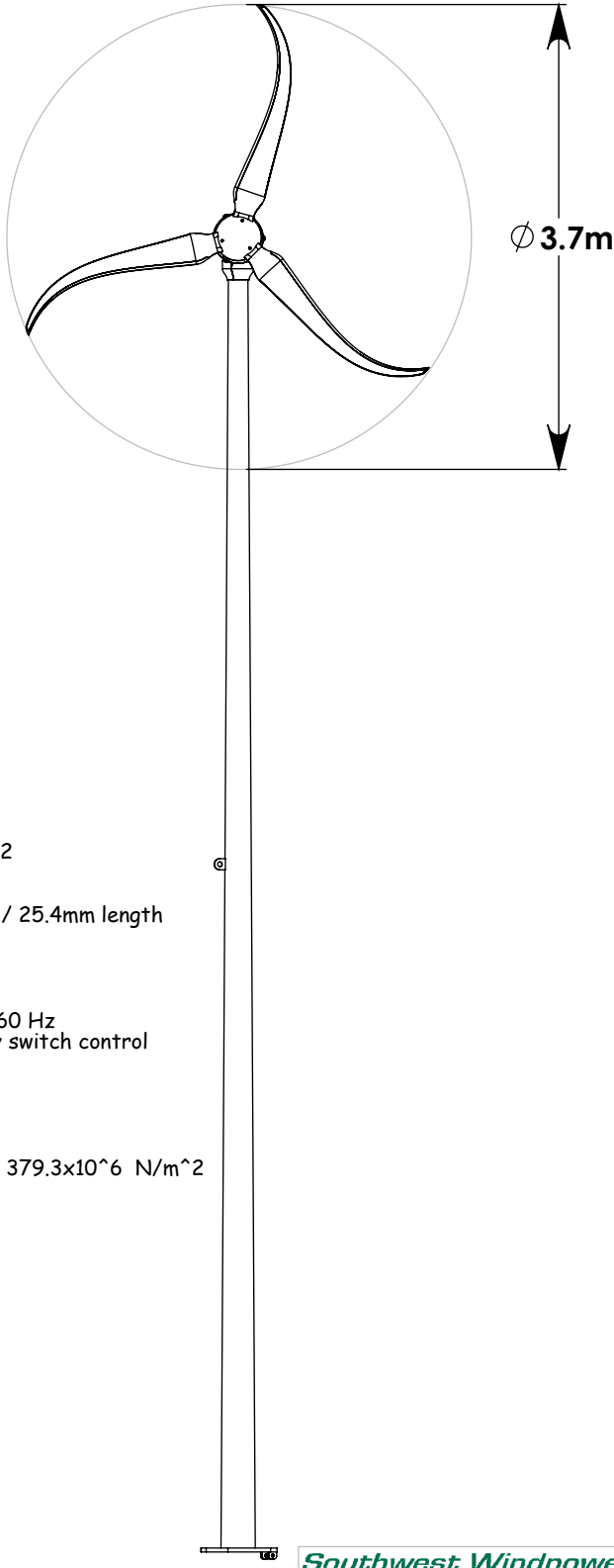
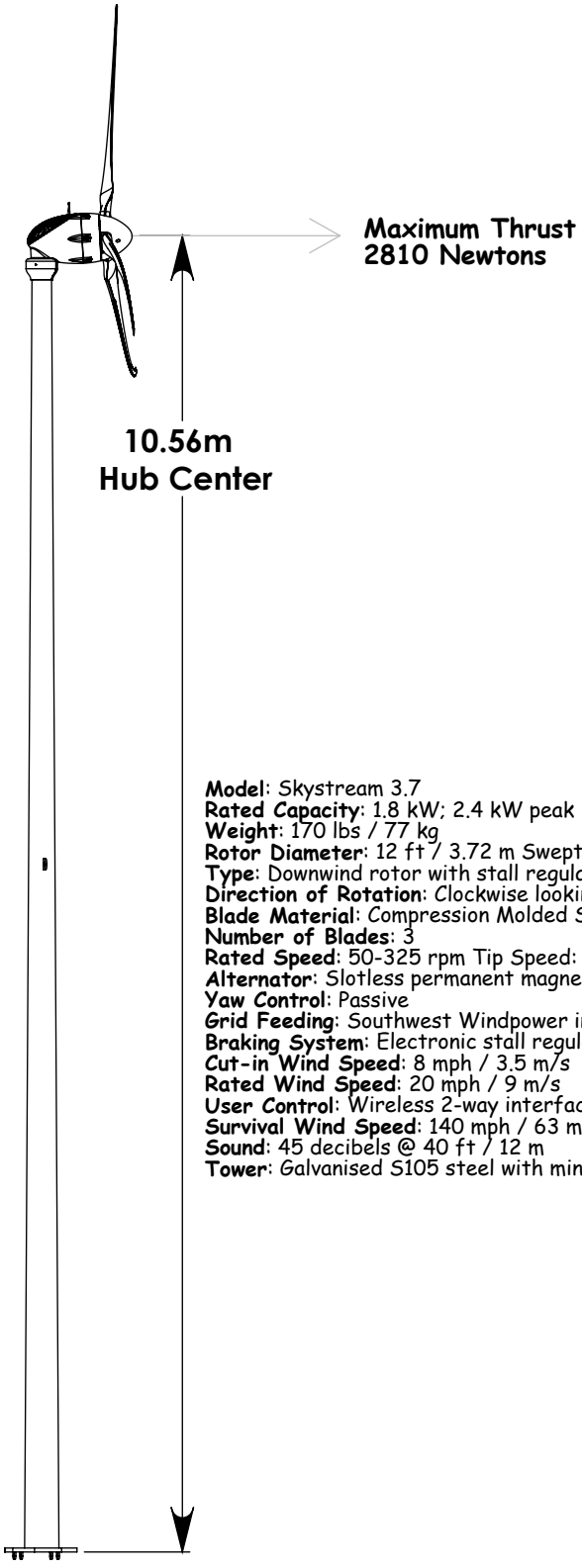

Model: Skystream 3.7
Rated Capacity: 1.8 kW; 2.4 kW peak
Weight: 170 lbs / 77 kg
Rotor Diameter: 12 ft / 3.72 m Swept Area: 115.7 ft² / 10.87 m²
Type: Downwind rotor with stall regulation control
Direction of Rotation: Clockwise looking upwind
Blade Material: Compression Molded SMC w/ 33% Glass fiber 1" / 25.4mm length
Number of Blades: 3
Rated Speed: 50-325 rpm Tip Speed: 66-213 ft/s / 9.7-63 m/s
Alternator: Slotless permanent magnet brushless
Yaw Control: Passive
Grid Feeding: Southwest Windpower inverter 120/240 VAC 50-60 Hz
Braking System: Electronic stall regulation with redundant relay switch control
Cut-in Wind Speed: 8 mph / 3.5 m/s
Rated Wind Speed: 20 mph / 9 m/s
User Control: Wireless 2-way interface remote system
Survival Wind Speed: 140 mph / 63 m/s
Sound: 45 decibels @ 40 ft / 12 m
Tower: Galvanised S105 steel with min. yield strength of 55 ksi / 379.3x10⁶ N/m²

Southwest Windpower
Flagstaff, Arizona U.S.A.

APPROVALS	DATE
DRAWN MGC	6/15/07
CHECKED	
RESP ENG	
MFG ENG	
QUAL ENG	

Skystream 3.7 Wind Turbine with 10.21m Hinged Monopole Tower

Skystream - 1.8 kW Wind Turbine

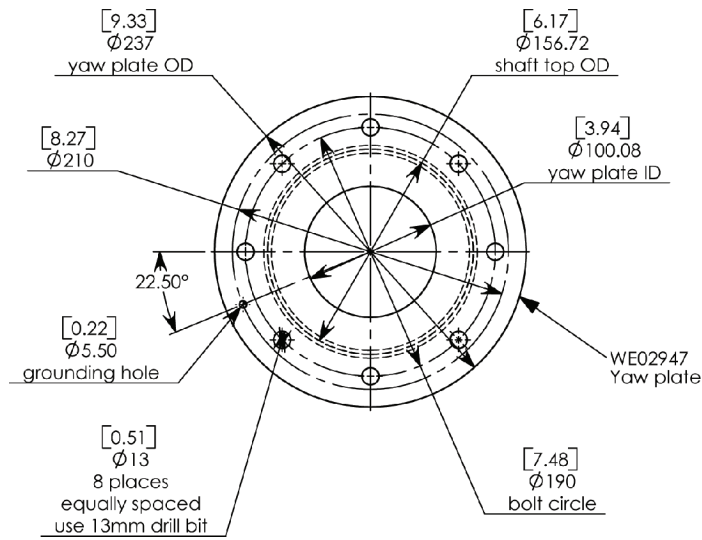
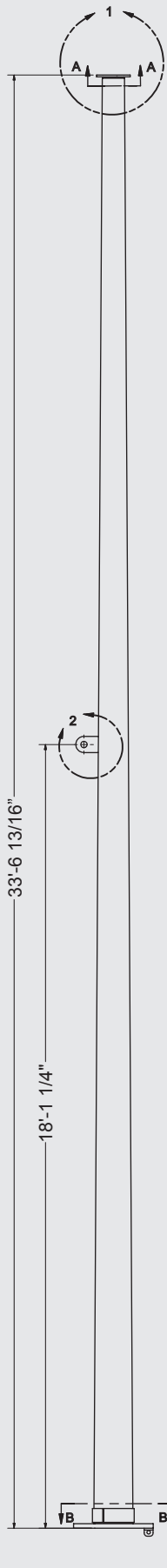

Tower Top

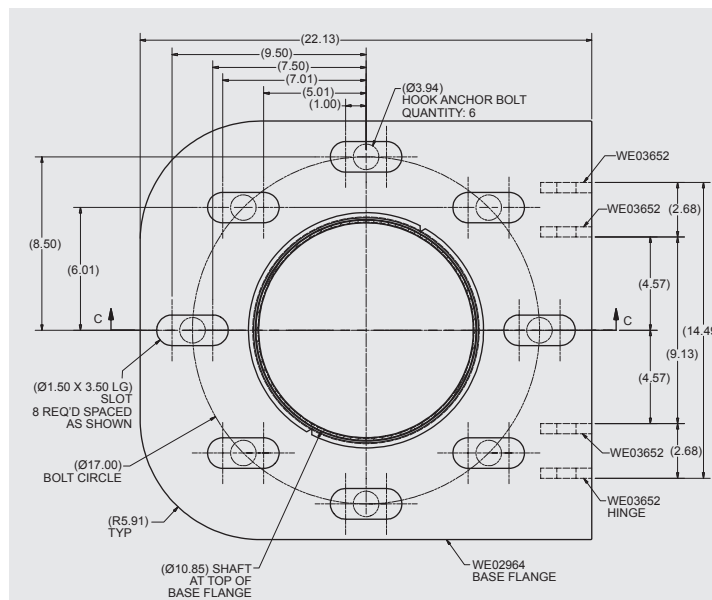

Tower Base

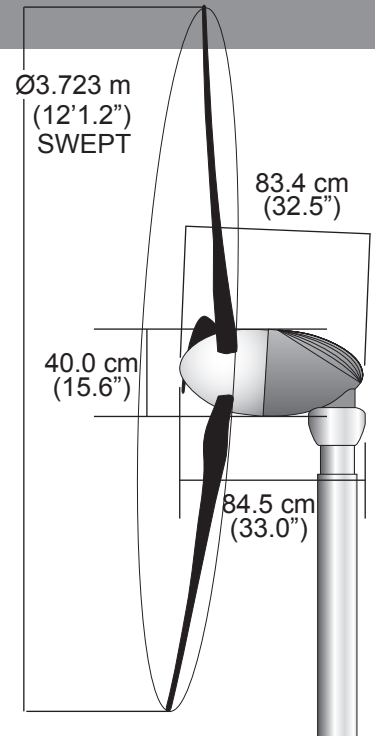

Dimensions

Prop Tip to Center of Tower: 780mm/30.7 in.
 Minimum Tip Clearance: 690mm/27.16 in.
 Max Tower Diameter at Tip: 171mm/6.75 in.

Wiring

Recommended Wire:
 90C (UL) Water Resistant or equivalent

Tower & Wind Generator Loading Specifications

Tower:	Freestanding Tapered Tubular Steel with Galvanized Finish
Tower Weight:	549 lbs/249.2 kg
Bottom of Tower Forces	
Center of Gravity:	400mm from center of tower
Axial Force:	3376 N (force due to tower and generator weight)
Overturing Bending Moment:	35611 Nm (includes wind loads)
Shear Force:	3851 N (includes wind loads)
Top of Tower Forces	
Thrust Load:	Average: 704
Design Shear Force:	2802 N (top of tower)
Peak Bending Moment:	1532 Nm
Downward Axial Force:	932 N (top of tower)